

THING TECH CO., LTD.

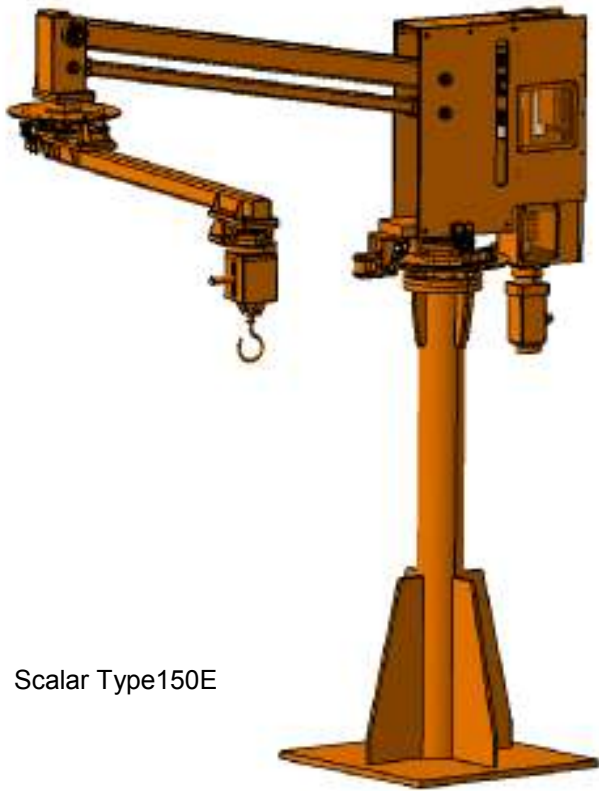

Scalar Type150E



Link Type 200BE

We'd developed Electric T-Arm series in addition to usual pneumatic T-Arm.

Capacities are from 40 to 650kg, according to pneumatic one.

You can choose control:

- Up/Down lever
- Step motion

You can choose arm:

- Scalar type(left picture)
- Link type(right picture)

We design your original attachment depends on your specification.

Up / Down lever



【T-Arm standard specification】

Size chart

Scalar type

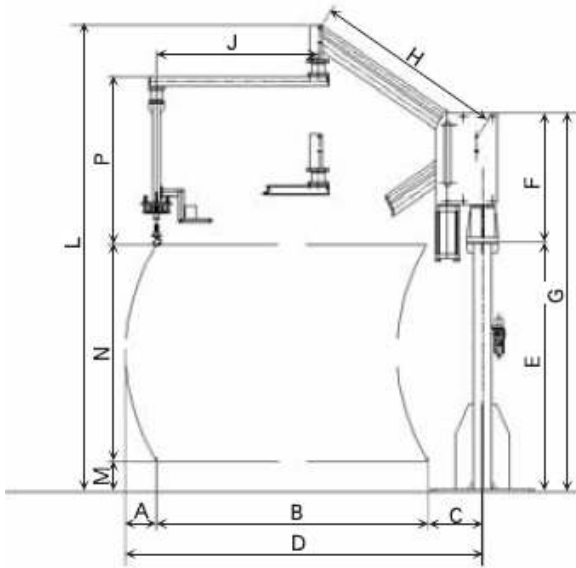

Type	Capacity	Power	A	B	C	D	E	F
Type 40	40 kg	0.75	225	1,600	400	2,225	2,000	650
Type 60	60 kg	0.75	230	1,850	400	2,480	2,000	870
Type 120	120 kg	1.2	230	1,850	400	2,480	2,000	970
Type 150	150 kg	1.2	230	1,850	400	2,480	2,000	970
Type 200	200 kg	1.2	200	2,150	400	2,750	2,000	1,080
Type 350	350 kg	3.1	200	2,000	545	2,745	2,160	1,180
Type	G	H	J	L	M	N	P	
Type 40	2,650	1,200	900	3,130	200	1,400	1,215	
Type 60	2,870	1,300	1,100	3,470	200	1,480	1,410	
Type 120	2,970	1,300	1,100	3,590	200	1,480	1,420	
Type 150	2,970	1,300	1,100	3,590	200	1,480	1,420	
Type 200	3,080	1,500	1,300	3,700	200	1,500	1,440	
Type 350	3,340	1,500	1,300	3,750	150	1,500	1,590	

- * A-P:mm
- * Power: 200V, KVA
- * We can supply the other type in each case.

Installed Bases

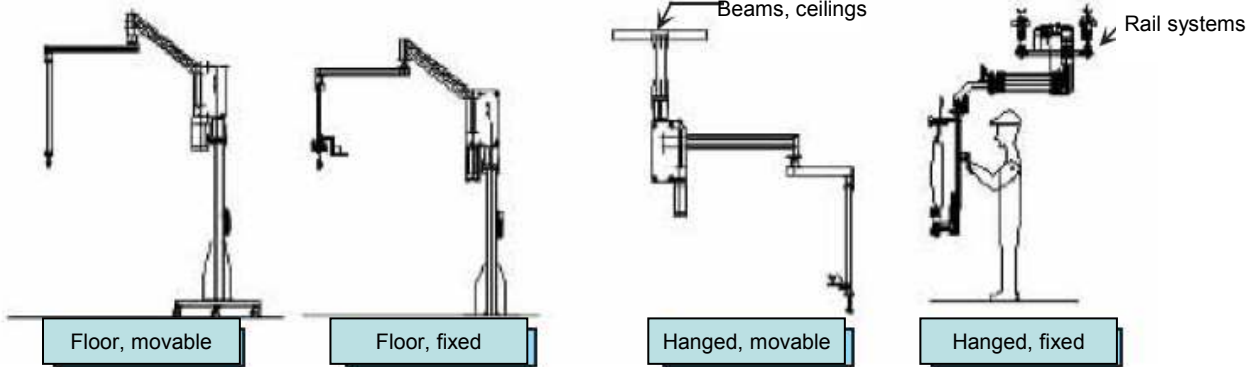

[Floor fixed base]
 Type:FPL-??(standard)
 (T-Arm's type)
 Ex: Type40→FPL40

[Floor movable base]
 Type:TPL-??(standard)
 (T-Arm's type)
 Ex: Type40→TPL40

[Hanged base]
 Type:RPL-??(quote in each case)
 (T-Arm's type)
 Ex: Type40→RPL40

Its specification is changed depends on installed position's situation.

Size chart

【T-Arm Standard Specification】

Link type

Type	Capacity	Power	A	B	C	D	E	F	G	L	N	P
Type 50BE	50 kg	0.75	1,792	208	300	1,750	1,995	672	2,667	3,647	1,450	1,835
Type 100BE	100 kg	1.2	1,792	208	300	1,800	2,010	720	2,730	3,690	1,450	1,890
Type 180BE	180 kg	1.2	1,785	215	300	2,000	1,920	1,015	3,018	3,950	1,450	1,915
Type 250BE	250 kg	1.9	1,770	230	300	2,000	1,997	1,021	3,080	3,700	1,450	2,120
Type 300BE	300 kg	3.1	1,770	230	300	2,000	1,997	1,021	3,020	3,950	1,450	2,120

* Power: 200V, KVA

* We can supply the other type in each case.

* A-P:mm

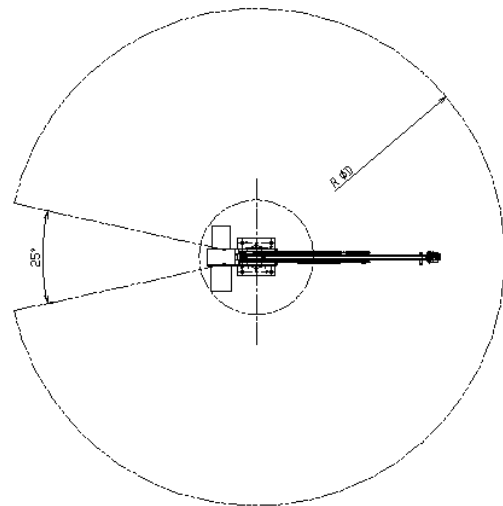
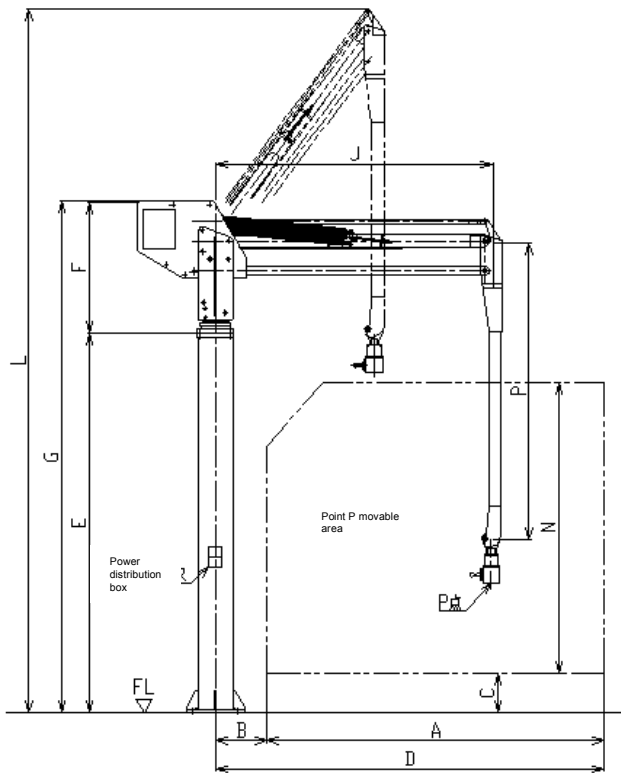

Control switches



Step Movement+Up/Down lever type



Up/Down lever

Attachment and options

We design your various attachment based on our experiences for electric T-Arm.



Clamp boxing products



Clamp feedstock



Clamp automobile component



Vacuum cardboard



Vacuum machinery parts



Clamp internal diameter of roll material

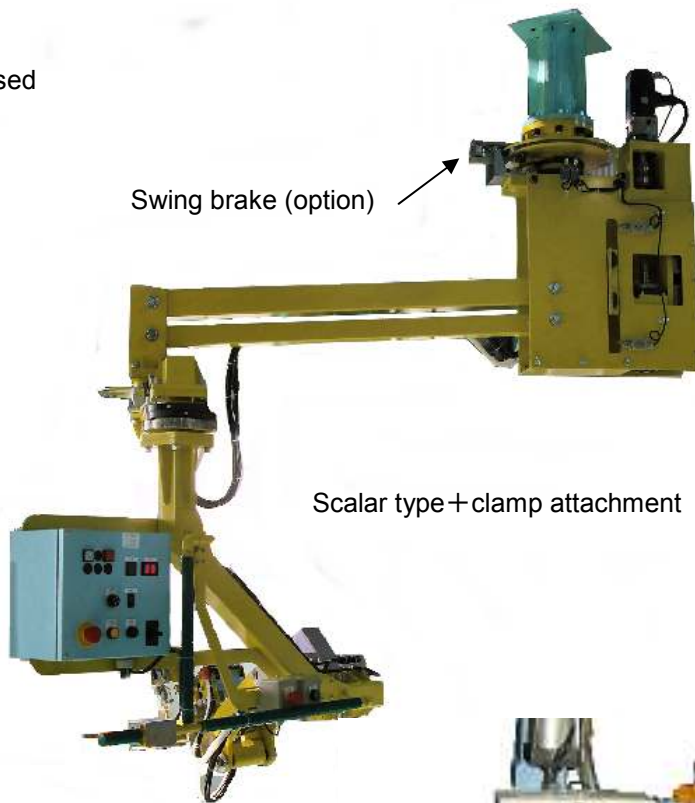

Swing brake (option)

Scalar type + clamp attachment

We can supply you various suggestions.